

Montaggio reggi profilo laterale per il trasporto
Side profile support assembly for transport

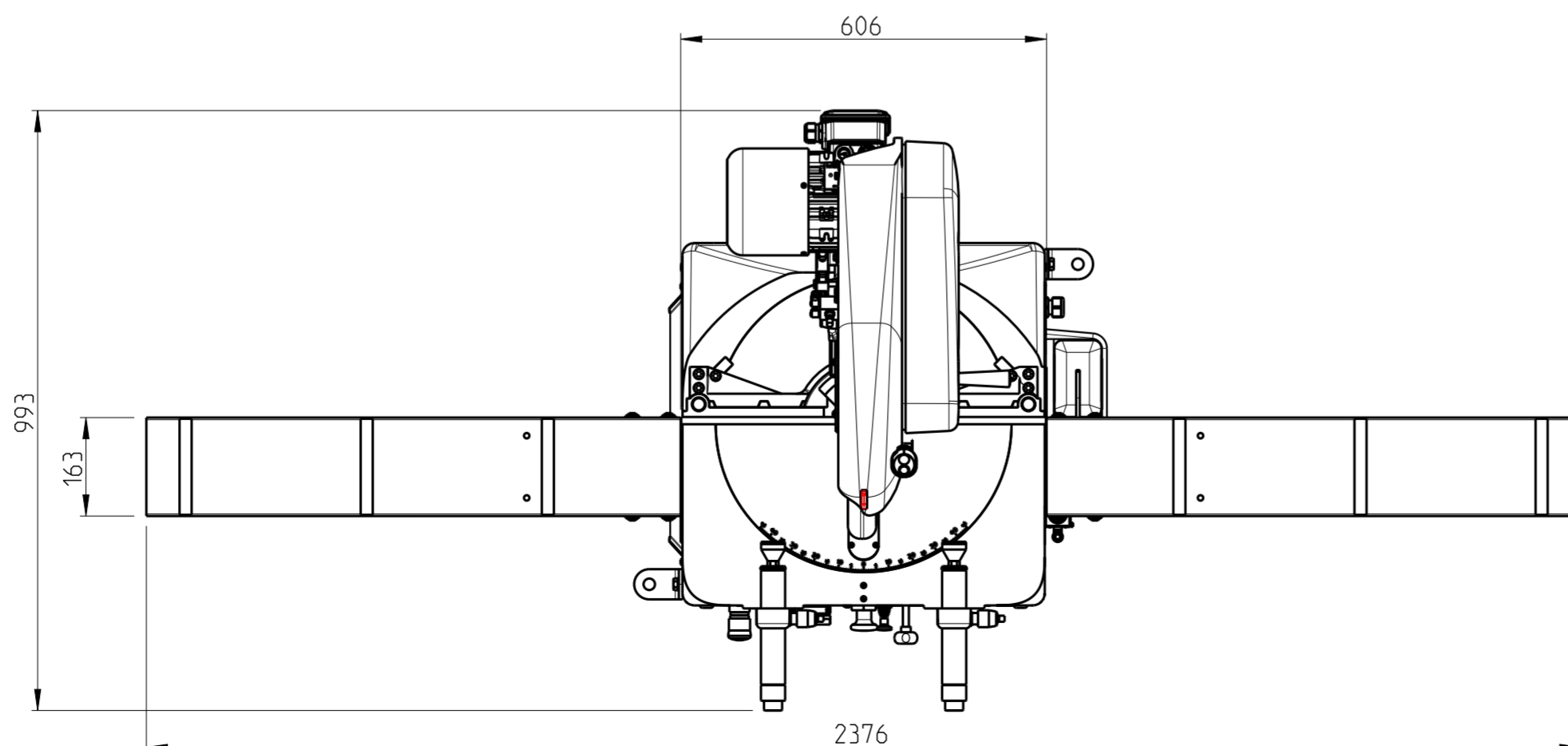
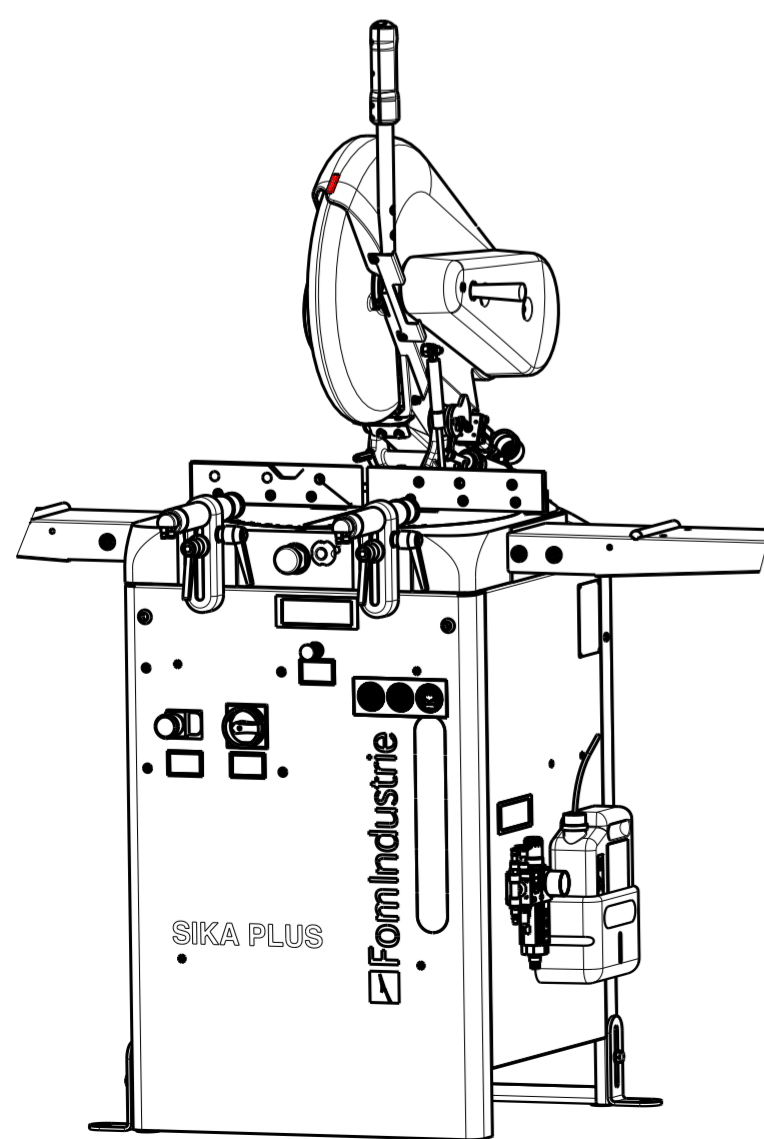

Pos	Codice/Code	Descrizione/Description	Rev	Peso/Weight (kg)	Qt
6	GF911807	Gruppo dotazioni Sika Plus Manuale	1	0.443	1
5	GF911783	Gruppo tanica olio No microgoccia	0	0.567	1
4	GF911762	Gruppo No microgoccia	0	0.251	1
3	GF911370	Gruppo testa manuale	0	47.002	1
2	GF911358	Gruppo piatto girevole	0	80.357	1
1	GF911355	Gruppo basamento versione manuale	2	50.798	1

Rev	Descrizione modifica / Change's description	Firma/Sign	Data/Date
1	Aggiornate viste disegno	EForcellese	19/05/2021

Data / Date	Disegnato / Designed	Controllato / Checked	Approvato / Approved
08/02/2018	EForcellese	MMorganti	MMorganti

Ricavato da / Get from	Trattamenti Termici / Heat Treatments	Peso/Weight (kg)	Scala/Scale	Rev. n°
		354.77	1:10	1

Descrizione / Description	Codice / Code
Studio troncatrice Sika Plus manuale Sika Plus manual sawing machine	XZ100228